

# **CONVEX VMEbus Ethernet Controller Service Guide**

Document No. 081-000630-200

---

---

First Edition  
June 1988

**CONVEX Computer Corporation**  
Richardson, Texas USA

*CONVEX VMEbus Ethernet Controller*  
*Service Guide*  
Order No. DHW-055  
First Edition

© 1988 CONVEX Computer Corporation  
All rights reserved

This document is copyrighted. All rights are reserved. This document may not, in whole or part, be copied, duplicated, reproduced, translated, electronically stored, or reduced to machine readable form without prior written consent from CONVEX Computer Corporation (CONVEX).

Although the material contained herein has been carefully reviewed, CONVEX does not warrant it to be free of errors or omissions. CONVEX reserves the right to make corrections, updates, revisions, or changes to the information contained herein. CONVEX does not warrant the material described herein to be free of patent infringement.

UNLESS PROVIDED OTHERWISE IN WRITING WITH CONVEX COMPUTER CORPORATION (CONVEX), THE EQUIPMENT DESCRIBED HEREIN IS PROVIDED "AS IS" WITHOUT WARRANTY OF ANY KIND, EITHER EXPRESSED OR IMPLIED, INCLUDING, BUT NOT LIMITED TO, THE IMPLIED WARRANTIES OF MERCHANTABILITY AND FITNESS FOR A PARTICULAR PURPOSE. SOME STATES DO NOT ALLOW THE EXCLUSION OF IMPLIED WARRANTIES. THE ABOVE EXCLUSION MAY NOT BE APPLICABLE TO ALL PURCHASERS BECAUSE WARRANTY RIGHTS CAN VARY FROM STATE TO STATE. IN NO EVENT WILL CONVEX BE LIABLE TO ANYONE FOR SPECIAL, COLLATERAL, INCIDENTAL, OR CONSEQUENTIAL DAMAGES, INCLUDING ANY LOST PROFITS OR LOST SAVINGS, ARISING OUT OF THE USE OR INABILITY TO USE THIS EQUIPMENT. CONVEX WILL NOT BE LIABLE EVEN IF IT HAS BEEN NOTIFIED OF THE POSSIBILITY OF SUCH DAMAGE BY THE PURCHASER OR ANY THIRD PARTY.

CONVEX and the CONVEX logo ("C") are registered trademarks of CONVEX Computer Corporation  
C1, C120, C210, C220, C230, and C240 are trademarks of CONVEX Computer Corporation  
UNIX is a registered trademark of AT&T Bell Laboratories  
EXOS is a registered trademark of Excelan, Inc.  
Excelan and NX are trademarks of Excelan, Inc.  
Ethernet is a trademark of Xerox Corporation

Printed in the United States of America

**Revision Sheet**  
*CONVEX VMEbus Ethernet Controller*  
*Service Guide*

<b>Edition</b>	<b>Document No.</b>	<b>Date</b>	<b>Description</b>
First	081-000630-200	June 1988	First release.

### **FCC NOTICE**

**Warning:** This equipment generates, uses, and can radiate radio frequency energy and if not installed and used in strict accordance with the instructions manual, may cause interference to radio communications. It has been tested and found to comply with the limits for a Class A computing device pursuant to Subpart J of Part 15 of FCC Rules, which are designed to provide reasonable protection against such interference when operated in a commercial environment. Operation of this equipment in a residential area is likely to cause interference in which case the user at his own expense will be required to take whatever measures may be required to correct the interference.

**Do not connect external equipment to the utility outlets in CONVEX equipment cabinets. Unauthorized connection voids all agencies' emissions certifications.**

# Table of Contents

<b>1 Description</b>	
1.1 Overview .....	1-1
1.2 Hardware Features .....	1-1
1.3 Ethernet Functions .....	1-2
1.3.1 Data-Link Layer Functions .....	1-2
1.3.2 Physical Layer Functions .....	1-2
1.4 Functional Description .....	1-3
1.4.1 Intel 80286 Microprocessor .....	1-4
1.4.1.1 Front-End Processor Mode .....	1-4
1.4.1.2 Link-Level Mode .....	1-4
1.4.2 Intel 82586 LAN Coprocessor .....	1-5
1.4.3 Serial Interface Adapter .....	1-5
1.4.4 Dual-Port RAM .....	1-5
1.4.5 EPROM-Resident NX 300 Network Executive .....	1-6
1.4.6 8259A Interrupt Controller .....	1-6
1.4.7 Host Interface .....	1-6
1.5 Diagnostics .....	1-7
1.6 Specifications for EXOS 302 .....	1-7
<b>2 Configuration and Installation</b>	
2.1 Overview .....	2-1
2.2 Inspection .....	2-1
2.3 Damage Claims .....	2-1
2.4 Electrostatic Discharge .....	2-2
2.5 Configuration .....	2-2
2.5.1 Base Address Jumper Selection .....	2-3
2.5.2 Request/Grant Level Jumper Settings .....	2-7
2.5.3 VMEbus Interrupt Request Jumper Setting .....	2-9
2.6 Removal and Installation .....	2-9
2.6.1 Extending the VMEbus Chassis .....	2-9
2.6.2 Removing the Ethernet Controller .....	2-11
2.6.3 Installing the Ethernet Controller .....	2-13
2.7 VMEbus Chassis Cable Scheme .....	2-15
2.8 Ethernet Cable Connections .....	2-16
2.8.1 Ethernet Ribbon-Cable Connection .....	2-16
2.8.2 Transceiver-to-Coaxial-Cable Connection .....	2-19
2.8.3 Transceiver Cable Connection .....	2-20
<b>3 Integration and Test</b>	
3.1 Overview .....	3-1
3.2 Software Integration .....	3-1
3.3 Example <i>/ioconfig</i> .....	3-1
3.4 Self-Test Operations .....	3-2
3.5 Diagnostics .....	3-4

# Appendixes

## A Reporting Problems

A.1 Overview .....	A-1
A.2 Information Required to Report a Problem .....	A-1

## List of Tables

1-1 VMEbus EXOS 302 Specifications .....	1-8
2-1 Static Charge Levels and Relative Humidity .....	2-2
2-2 Ethernet Controller Address Jumper Positions .....	2-3
2-3 Cable Opening Numbers for VMEbus Chassis .....	2-15
3-1 Self-Diagnostic/Configuration Error Codes .....	3-3

## List of Figures

1-1 VMEbus EXOS 302 Architecture .....	1-3
2-1 Ethernet Address FD80 .....	2-4
2-2 Ethernet Address FE00 .....	2-5
2-3 Ethernet Address FE80 .....	2-6
2-4 Ethernet Address FF00 .....	2-7
2-5 CONVEX Standard Ethernet Jumper Settings .....	2-8
2-6 VMEbus Chassis Power Switch .....	2-10
2-7 Expansion Cabinet Stabilizer Bars .....	2-11
2-8 Ethernet Board Removal .....	2-12
2-9 Single (6U) VMEbus Circuit Board Adapter .....	2-14
2-10 Ethernet Controller Ribbon-Cable Connection .....	2-17
2-11 Ethernet Ribbon-Cable to VMEbus Chassis .....	2-18
2-12 Transceiver-to-Coaxial-Cable Connection .....	2-19
2-13 Transceiver Cable Connection .....	2-21
3-1 Example <i>/ioconfig</i> .....	3-2
A-1 Sample <i>contact</i> Session .....	A-3

# Preface

## Purpose and Intended Audience

This manual provides a general description of the VMEbus Ethernet controller. The following areas are discussed:

- General description of VMEbus Ethernet controller operation
- Installation of the VMEbus Ethernet controller
- Integration of the VMEbus Ethernet controller into the CONVEX Operating System (OS)

This manual is for CONVEX field engineers, manufacturing personnel, and customers installing and maintaining this equipment. This manual is a subset of the VMEbus service kit.

## Hardware and Software Requirements

The VMEbus Ethernet controller can be used with all CONVEX computers that have a VMEbus chassis installed.

Diagnostic program *dev5500* is used to verify the proper operation of the VMEbus Ethernet.

## Organization

The content of each chapter is outlined below:

- **Chapter 1. Description** — Describes the VMEbus Ethernet controller and lists the electromechanical and environmental specifications
- **Chapter 2. Configuration and Installation** — Describes inspection and reporting of damage and provides instructions on how to configure and install the VMEbus Ethernet
- **Chapter 3. Integration and Test** — Explains the integration of the VMEbus Ethernet controller into the OS and provides information on diagnostic tests for the Ethernet controller
- **Appendix A. Problem Reporting** — Contains information concerning how to use the *contact* facility to report problems

## Notational Conventions

The following are examples of warnings, cautions, and notes and their typical content and locations as used in CONVEX documents:

**WARNING**

Warnings highlight procedures or information necessary to avoid injury to personnel. Warnings immediately precede the critical information and include a description of the hazard.

**CAUTION**

Cautions highlight procedures or information necessary to avoid damage to equipment, damage to software, or loss of data, or invalid test results. Cautions immediately precede the critical information and include a description of the possible damage.

**NOTE**

Notes highlight information of a supplemental nature. They immediately precede or follow the highlighted information.

## Associated Documents

The following partial list of manuals may provide more detailed information on the VMEbus Ethernet system:

- *NX 300 Network Executive Reference Manual*, Excelan Inc., Publication No. 4200036-00
- *EXOS 302 Intelligent Ethernet Controller for VMEbus Systems Reference Manual*, Excelan Inc., Publication No. 4200069-00
- *CONVEX System Manager's Guide*, Order No. DSW-004
- *CONVEX PBUS I/O System Diagnostics Manual*, Order No. DHW-008
- *CONVEX Processor Operations Guide (C1, C120, C130, C210, C220)*, Order No. DHW-015

## Ordering Documentation

To order the most current version of this or any documents, use the order number. If the order number is not known, order by the exact title. In some situations the most current version may not be desired. To receive a specific version of a manual, order the manual by its 12-digit document, or part number, which can be obtained by contacting the local CONVEX office or by calling the Technical Assistance Center.

The order number for this manual is DHW-055.  
The document number for this manual is 081-000630-200.

CONVEX documents can be ordered by mail by sending a request to:

CONVEX Computer Corporation  
Customer Service  
PO Box 833851  
Richardson TX 75083-3851 USA

## Technical Assistance

Hardware and software support can be obtained through the CONVEX Technical Assistance Center (TAC). In Texas, the TAC can be reached in Texas by calling (214) 952-0379. From other locations in the continental United States call 1(800) 952-0379. Customers outside the United States should contact their local CONVEX office.

**THIS PAGE INTENTIONALLY LEFT BLANK**

# Chapter 1

## Description

### 1.1 Overview

This chapter briefly discusses the major features and operating functions of the Ethernet controller:

- **Hardware features** — Presents the main features of the Ethernet controller
- **Ethernet Functions** — Describes the functions associated with the use of the EXOS 302 controller
- **Functional description** — Discusses initial software setup requirements, and presents a brief overview of the sequence of operation
- **Interface** — Describes the basic interface between the Ethernet, disk drive, and VMEbus
- **Diagnostics** — Describes the controller's on-board diagnostics
- **Specifications** — A tabular presentation of the electromechanical and environmental specifications for the Ethernet controller

---

**NOTE**

For a detail description of the Ethernet controller, refer to the *EXOS 302 Intelligent Ethernet Controller for VMEbus Systems Reference Manual*.

---

### 1.2 Hardware Features

The Ethernet controller (EXOS 302) is a microprocessor-controller adapter which provides an ethernet connection for computers using the VMEbus. The EXOS 302 operates as a bus master, capable of reading and writing the host memory. Coordination between the host and the controller is accomplished by the establishment of control blocks in host memory, the passing of value via special registers, and interrupts. The controller also operates as a slave to a bus master reading or writing control registers.

The main hardware features of the VMEbus EXOS 302 are:

- Onboard Intel 80286 microprocessor running at 8 MHz and with 512 Kbytes of RAM to support the high-level network protocols
- Dual-port memory that allows concurrent, full-speed access by the onboard microprocessor and Local Area Network (LAN) coprocessor

- Uses hardware logic for recognition of physical, broadcast, and multiple multicast addresses, in addition to promiscuous mode
- Hardware-supported buffer chaining (allocation is completely under software control) that allows buffering of an arbitrary number of received frames without any CPU intervention
- A single (6U) VMEbus circuit board with front panel and ejectors

## 1.3 Ethernet Functions

The EXOS 302 performs all *physical* and *data-link layer* functions, except for transceiver functions:

- Serial-to-parallel and parallel-to-serial conversions
- Address recognition
- Framing and unframing of messages
- Manchester coding and decoding
- Preamble generation and removal
- Carrier sense and deference
- Collision detection and enforcement, including jamming, backoff, timing, and retry
- Frame Check Sequence (FCS) and Cyclic Redundancy Check (CRC) generation and verification
- Physical and multicast address recognition
- Alignment and length error detection and handling

### 1.3.1 Data-Link Layer Functions

The *data-link layer* controls a single channel with data segmented into groups of data bits (a specified number). Additional bits (a header and trailer) are added to the groups to form frames or packets. This function usually involves specialized electronics in the interface, and some intelligence in the station-to-station network interface. It is the multi-end point connection between the higher-layer entities wishing to communicate to the host system.

### 1.3.2 Physical Layer Functions

The *physical layer* concerns the transmission of the bits on the media, thereby involving mechanical/electrical concerns and dealing with the hardware. The *physical layer* in the CONVEX Ethernet LAN is comprised of the Serial Interface Adapter (SIA) and the coaxial cable to the transceiver. This layer completely specifies the essential physical characteristics of the Ethernet, such as data encoding, timing, voltage levels, etc.

## 1.4 Functional Description

Functioning as a high-performance, front-end communications processor, the EXOS 302 connects the VMEbus system to an Ethernet LAN. The LAN provides a communications facility for high-speed data exchange between computers and other digital devices located within a specific geographical area (generally within one facility).

Two modes of operation are available when using the EXOS 302. Operation is either as an intelligent front-end processor or as a link-level controller. When used as a front-end processor, the EXOS 302 executes the high-level network protocols onboard, offloading this burden from the host CPU. As a link-level controller, the EXOS 302 extends the standard Ethernet data-link interface to the host system. In a typical LAN based on Ethernet standards, a host computer system is connected to the network through the EXOS 302 and a transceiver. The following figure presents the basic architecture of the EXOS 302:

Figure 1-1, VMEbus EXOS 302 Architecture

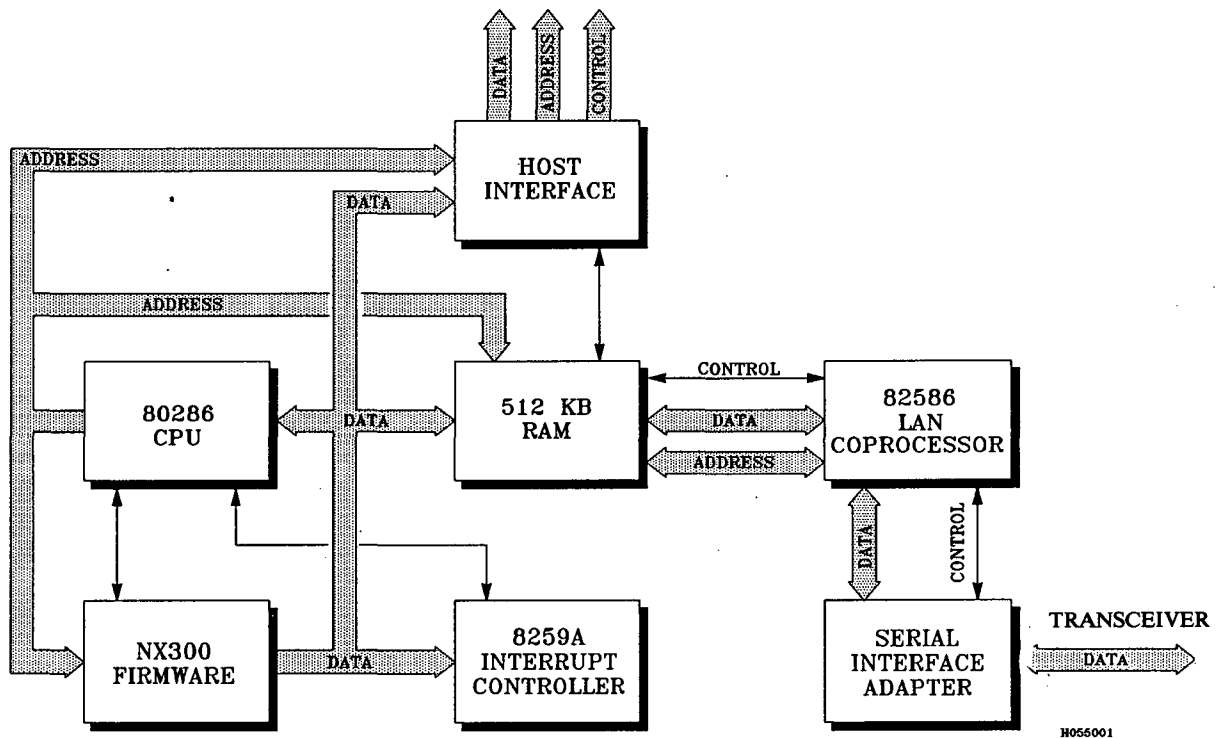

All processing of data to the host system is through request/grant level 3, the CONVEX standard for all processing in the VMEbus subsystem. Data processing operations through the EXOS 302 is handled by the following major components:

- Intel 80286 microprocessor
- Intel 82586 LAN coprocessor
- Dual-port 512 Kbytes RAM
- EPROM-resident NX 300 network executive
- Intel 8259A interrupt controller
- Serial interface adapter
- Host bus interface

### 1.4.1 Intel 80286 Microprocessor

Managing the data packets from the host interface is the primary function of the Intel 80286 microprocessor. As a subfunction this processor interfaces with the 82586 LAN coprocessor. The 80286 microprocessor executes the NX 300 firmware and the protocol software, downloaded to the EXOS 302 either from the host or over the network. Two resident EPROMS containing the NX 300 firmware provide the software access to the Ethernet network.

Communications between the host system and the EXOS 302 is primarily through command and reply messages. Relieving the host of monitoring interrupts to and from the coaxial cable, the 80286 microprocessor executes the sending and receiving of command messages and passes them on to the host system. Software executed by the 80286 interprets the messages and generates the replies to the host system. The 80286 is capable of operating in two basic modes:

- Front-end processor mode
- Link-level controller mode

#### 1.4.1.1 Front-End Processor Mode

Operating in the front-end processor mode, the host system downloads the protocol software to the EXOS 302 at initialization (or optionally, the EXOS 302 bootstraps itself to the Ethernet). The 80286 uses this software and the NX 300's real-time, multitasking process management services and I/O drivers to control the the Ethernet interface and to manage the communications with the host system.

#### 1.4.1.2 Link-Level Mode

In the link-level controller mode, the NX 300 provides the 80286 with a standard Ethernet data-link interface to the host system. The host system selects the link-level controller mode during initialization. Instead of the host downloading protocol software, as in the front-end processor mode, the 80286 calls the NX 300 to run firmware to bring the onboard Ethernet driver out to the host interface. The host can then access all Ethernet functions through request and reply messages. The 80286 controlling the NX 300 firmware uses the Ethernet controller's RAM primarily to buffer packets in both directions between the network and the host.

**NOTE**

Programming information required to write I/O drivers to interface host-resident protocol software to the NX 300 data-link functions is described in detail in the *NX 300 Network Executive Reference Manual*.

### 1.4.2 Intel 82586 LAN Coprocessor

The main functions of the 82586 LAN coprocessor is to acknowledge interrupts from the Serial Interface Adapter (SIA) and to provide the service of taking data packets from and putting data packets into memory. Output data packets are retrieved from memory by the 82586 and sent out to the SIA for conversion. Incoming data packets are acknowledged by the 82586 through receipt of an interrupts from the SIA. Acknowledging the interrupts, the 82586 retrieves the incoming data packet from the SIA and places the packet into memory.

### 1.4.3 Serial Interface Adapter

The Serial Interface Adapter (SIA) provides the *physical layer* channel through the coaxial cable medium. The SIA specifies the essential physical characteristics of the Ethernet. Such characteristics involve the coding and decoding of the data packets enabling communication between respective stations and the *data-link layer*. The SIA performs two main functions:

- Serialize the data going out to transceiver
- De-serialize the data to the LAN coprocessor

The SIA serializes data packets received from the LAN coprocessor before sending to the transceiver. A Manchester encoding technique blends all clock and data together to form a serial stream. This serial stream data then passes over the cable to the transceiver.

The SIA interrupts incoming serial streams from the transceiver are. Serial stream data filters through the SIA Manchester recovery circuit where clock and data are separated and prepared for output to the LAN coprocessor. Before transferring data to the LAN coprocessor, the SIA sends an interrupt signal indicating that data packets are available. The 82586 microprocessor acknowledges the interrupt and transfers the data to memory.

### 1.4.4 Dual-Port RAM

Storing downloaded protocol software and data packets is the main function of the 512-Kbytes RAM. Dual-porting allows for the operation of retrieving and inputting data by either the 80286 microprocessor or the 82586 LAN coprocessor. Transmission of data packets between the RAM and the VMEbus is under the control of the 80286 microprocessor. The 82586 LAN coprocessor controls data packets retrieved from the RAM for output to the coaxial cable and receipt of packets on the coaxial cable for memory.

Memory on the EXOS 302 controller can be accessed by the host interface; however, control of the RAM is through the 80286 microprocessor.

### 1.4.5 EPROM-Resident NX 300 Network Executive

The NX 300 firmware provides diagnostics, interfaces to host memory and the LAN coprocessor, and operating environments for execution of the protocol software. It also provides link-level controller functions that allow the protocols to reside in the host. The host system and the Ethernet controller communicate primarily through command and reply messages located in the host memory, which is accessible from the VMEbus. The NX 300 firmware interprets the command messages and generates replies. The NX 300 firmware attaches to the 80286 microprocessor by the data bus, address, and control lines.

Program functions for operation of the 80286 microprocessor are provided by the NX 300 firmware. When in the front-end mode, the NX 300 firmware provides the real-time, multi-tasking process management services and I/O drivers to control the interface and manage the communications to the host system.

Used as a link-level controller, the host system obtains data link services through the standard request and reply messages. The NX 300 performs system tasks of processing and transferring data between the host and the EXOS 302, and executes the users processes and system communications. It also includes functions to assist network management, determine controller mode, define memory locations, and provide data order conversions.

The NX 300 uses the 82586 LAN coprocessor on the EXOS 302 to implement the Ethernet data-link protocol. In order to ensure that the CPU is fully available for front-end processing applications, functions such as address recognition, CRC check, and buffer chaining are managed by the hardware.

### 1.4.6 8259A Interrupt Controller

Providing up to seven different interrupt levels, the 8259A interrupt controller monitors system interrupts for each specific function. Its capability allows each interrupt, 1 through 7, to represent a specific type of interrupt for onboard functions. As interrupts are detected, the 8259A sends an interrupt vector to the 80286 microprocessor to indicate what function is being interrupted.

### 1.4.7 Host Interface

Host interfacing with EXOS 302 components are linked through the 80286 microprocessor and the 512 Kbytes RAM memory. Whenever the EXOS 302 requests an interface to the host, the request *must* be a request/grant level 3 for CONVEX systems. VMEbus slots are always chained with request/grant level 3. Communications between the host processor and the EXOS 302 is conducted via a coordinated exchange of interrupts, I/O instructions, and data transfers through shared memory on the VMEbus.

Interrupt priorities for VMEbus are set at level 1 through level 7 by using the onboard jumpers. Refer to Chapter 2 for the location and proper setup of a specific jumper setting for a typical CONVEX system. Interrupt level 5 is the recommended interrupt level for CONVEX VMEbus systems. Refer to the *EXOS 302 Reference Manual* for interrupt configuration.

## 1.5 Diagnostics

The Ethernet executive firmware performs a series of tests that exercise the hardware and software components. In addition to ensuring the Ethernet controller is functioning properly, these tests can isolate specific hardware or software errors associated with configuration or operation. The errors are indicated by an LED, making it possible for them to be identified and corrected.

When the Ethernet executive is reset either by the initialization signal or by host software, the firmware runs comprehensive diagnostic tests on the controller components. Completion of the tests means the board is ready for configuration. If any of the diagnostic tests fail, it is reported to the host via the I/O port. Refer to the *EXOS 302 Intelligent Ethernet Controller for VMEbus Systems Reference Manual* for the self-diagnostics and configuration error codes. Diagnostics included on the EXOS 302 controller are:

- Memory read and write tests
- Send and receive
- Cyclic Redundancy Check (CRC)
- Hard and soft interrupts
- Checksum of the NX 300 firmware

## 1.6 Specifications for EXOS 302

The following table presents the specifications of the VMEbus Ethernet controller:

**Table 1-1, VMEbus EXOS 302 Specifications**

Parameter	Value
Width	6.30 in (160 mm)
Length	9.20 in (233 mm)
Thickness	0.77 in ( <i>approx</i> ) (19.6 mm)
Weight	1.01 lb ( <i>approx</i> ) (0.45 kg)
DC Voltage Requirements	+5 VDC @ 6.0 A Max +12 VDC @ 0.5 A Max (for transceiver and serial port) -12 VDC @ 0.05 A Max (for serial port only)
Temperature Range, Maximum	41 °F to 122 °F (5 °C to 50 °C)
Temperature Range, Recommended <sup>1</sup>	70 °F to 80 °F (21 °C to 26.6 °C)
Rate of Temperature Change, Maximum <sup>2</sup>	18 °F/hr (10 °C/hr)
Humidity Range, Maximum	0% to 90% with no condensation
Humidity Range, Recommended	40% to 60% with no condensation

<sup>1</sup> At altitudes above 3,280 ft (1,000 m), lower air densities affect air conditioning. If the unit is located above this altitude, lower the recommended temperature range by 1 °F/1,000 ft (2 °C/1,000 m).

<sup>2</sup> This is the maximum rate of change for the CONVEX VMEbus EXOS 302. However, the maximum rate of change for the system containing the controller may be less.

# Chapter 2

## Configuration and Installation

### 2.1 Overview

This chapter describes the procedures to remove or install the VMEbus Ethernet Controller into the VMEbus chassis. The cabling scheme, onboard jumper positions, and address selections are discussed in detail to ensure proper installation.

### 2.2 Inspection

#### CAUTION

The Ethernet controller is extremely sensitive to Electrostatic Discharge (ESD). Use appropriate measures when handling the board. Wear a wrist ground strap or other grounding device when unpacking and inspecting the Ethernet controller.

The package for shipping the Ethernet controller is specially designed to protect the board against electrostatic damage. Inspect the package on receipt for signs of damage during shipment. Remove the board from the package and carefully examine the board for damaged components. Document any damage and refer to the following section.

#### NOTE

Save all packaging material until after operational checkout of the board. This enables the board to be returned should problems exist.

### 2.3 Damage Claims

If the board is damaged in shipment, a damage claim must be completed. Damage claims should be prepared by the customer and given to the shipping representative. Claims forms may be obtained from the shipping representative.

## 2.4 Electrostatic Discharge

Static charge takes place when various objects are separated or rubbed together, often creating high voltage levels. The main factors that determine a voltage charge are:

- Types of materials
- Relative humidity
- Rate of change or separation

### WARNING

The Ethernet controller is extremely sensitive to Electrostatic Discharge (ESD). Use appropriate measures when handling the board. Wear a wrist ground strap or other grounding device when installing or performing maintenance on the Ethernet controller.

Ethernet controllers are sensitive to static electricity, due to the electrostatically-sensitive devices used within the circuitry. Controllers can be damaged by an ESD caused during maintenance procedures, such as installation. Use proper care when handling or performing maintenance on or around the controller board. To avoid damage to electronic devices, service personnel must observe the warnings when servicing the Ethernet controller board.

The following table presents examples of charge levels based on various activities and humidity levels:

**Table 2-1, Static Charge Levels and Relative Humidity**

Personnel Activity	Humidity & Charge Levels (Volts)			
	20%	32%	40%	50%
Person walking across linoleum floor	6,150V	5,750V	4,625V	3,700V
Person walking across carpet	18,450V	17,250V	13,875V	11,100V
Person getting up from a plastic chair	24,600V	23,000V	18,500V	14,800V

## 2.5 Configuration

Before installing the Ethernet controller, it *must* be configured to the address, bus request/grant, and interrupt level settings for use in the system. Base addresses for the controller are determined by setting a series of jumpers on the board. Jumpers also establish the bus request/grant levels and interrupt levels for operation of the controller within a system.

### 2.5.1 Base Address Jumper Selection

Jumper settings on the Ethernet controller determines the base address of the board as it is configured for the system being installed. Jumpers 42 and 43 are used in combination to establish the appropriate address configuration. The following table presents the available address settings using jumpers 42 and 43 in combination. These jumpers must be configured before installation.

**Table 2-2, Ethernet Controller Address Jumper Positions**

Address Jumper Positions		
Address Setting	Jumper 42	Jumper 43
FD80	Removed	Removed
FE00	Installed	Removed
FE80	Removed	Installed
FF00	Installed	Installed

Jumper configurations and location of jumpers for CONVEX base addresses are presented in the following figures for each Ethernet controller address. The base address *must* be configured on the controller before installing in the system.

Figure 2-1, Ethernet Address FD80

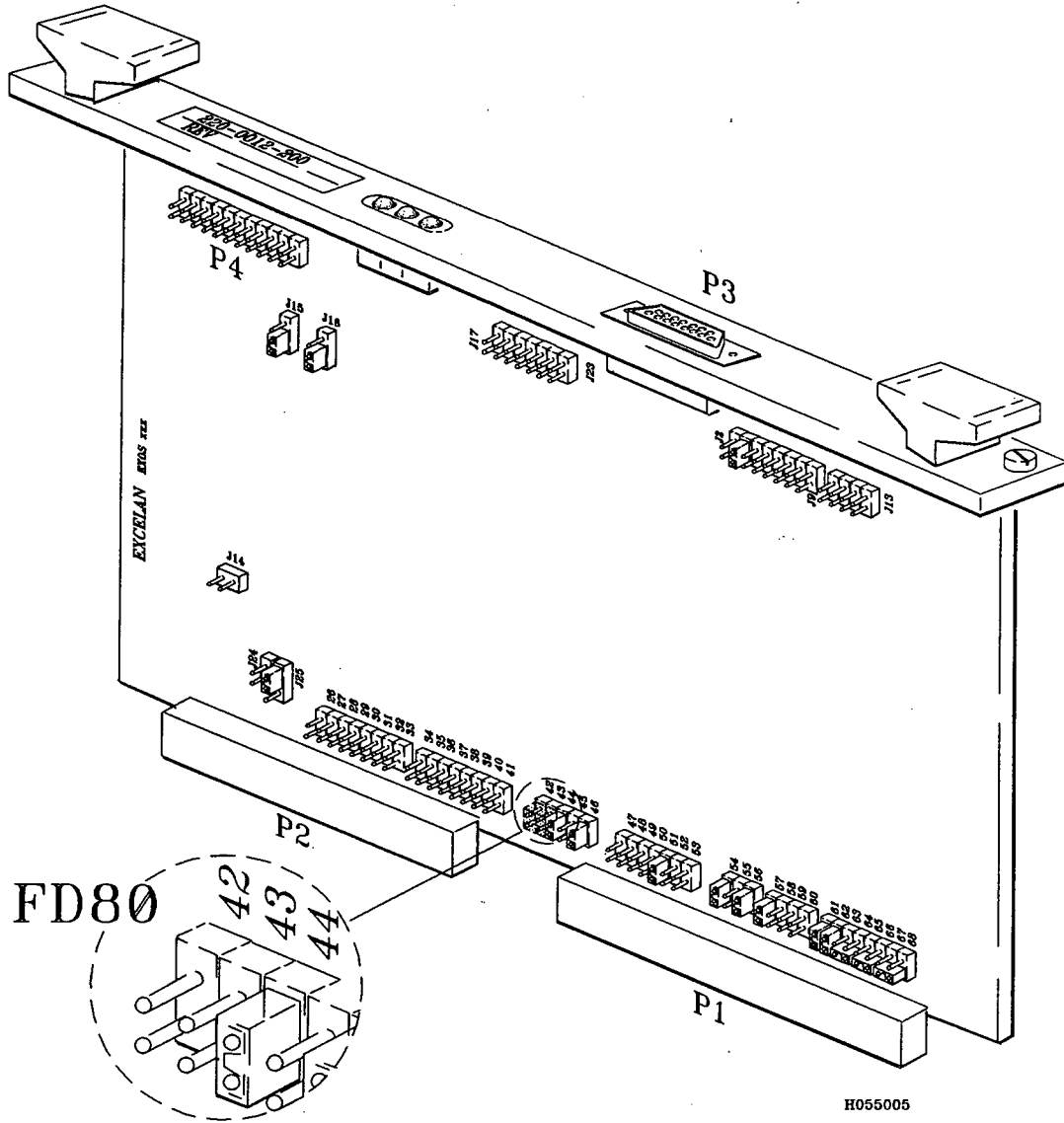

Figure 2-2, Ethernet Address FE00

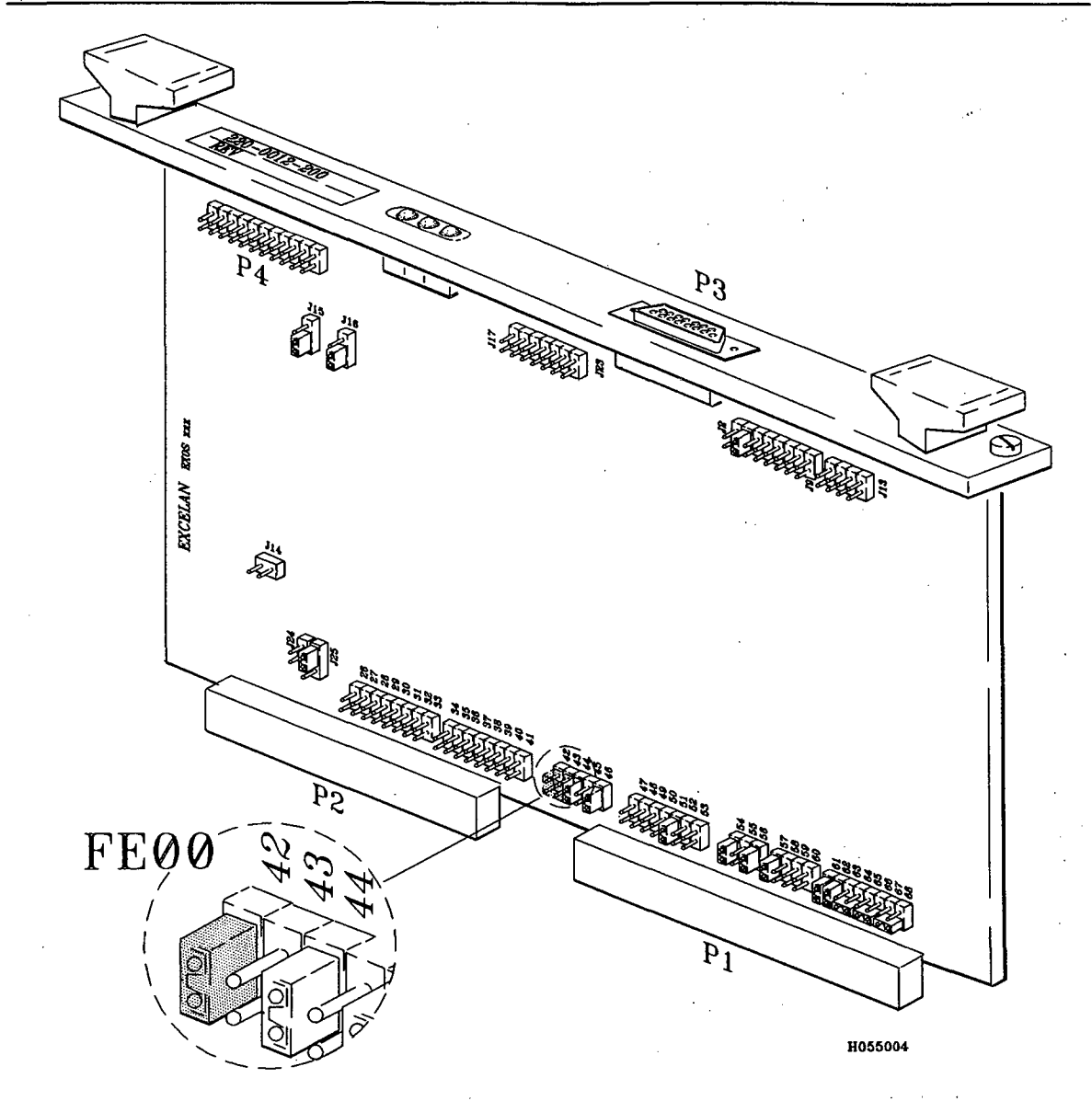
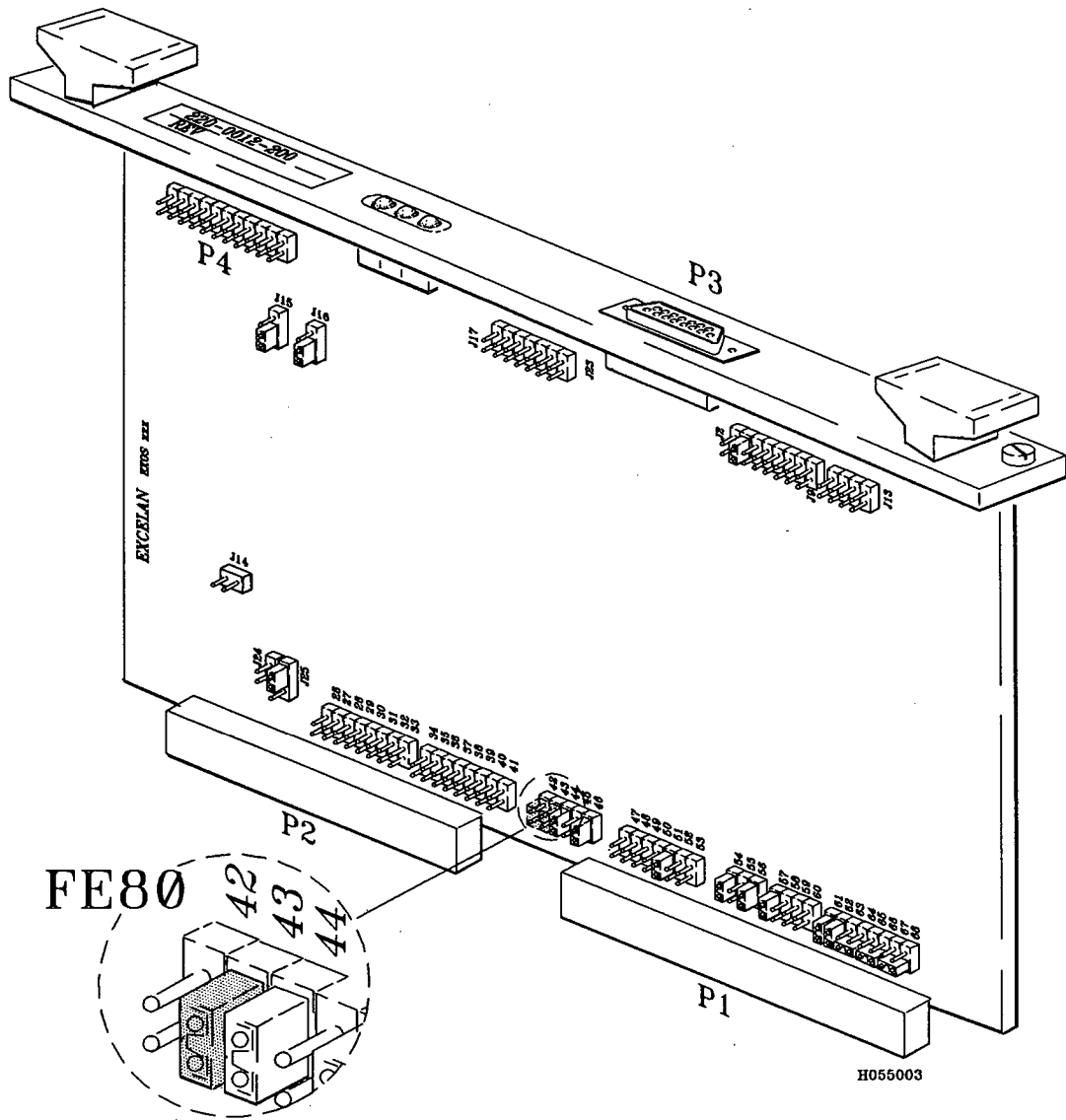
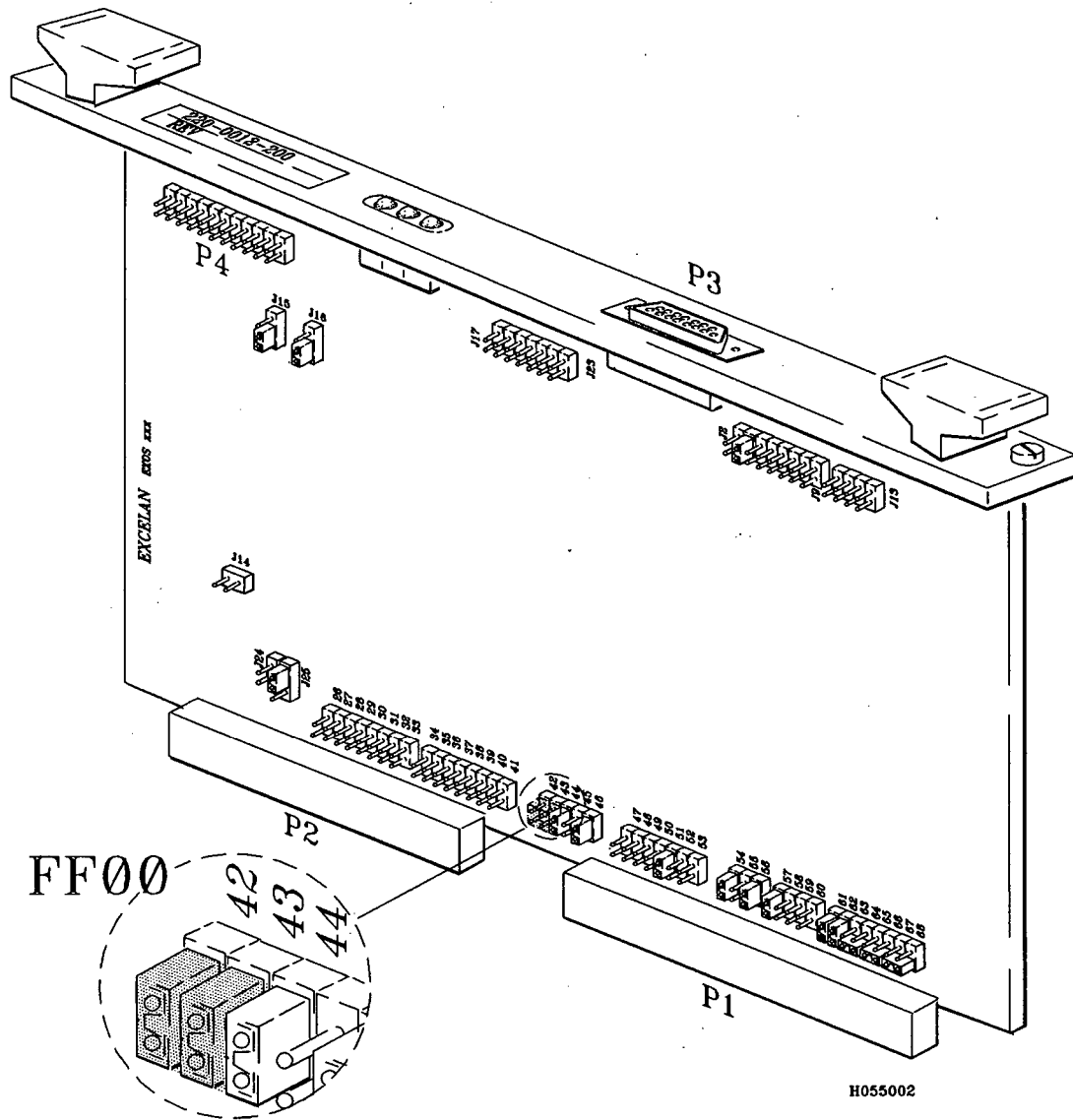

Figure 2-3, Ethernet Address FE80



**Figure 2-4, Ethernet Address FF00**



### 2.5.2 Request/Grant Level Jumper Settings

CONVEX VMEbus controllers use the bus request/grant level 3 (highest) jumper configuration. Jumper J57 is used to select VMEbus request/grant level 3 on the Ethernet controller as shown in the following figure:

Figure 2-5, CONVEX Standard Ethernet Jumper Settings

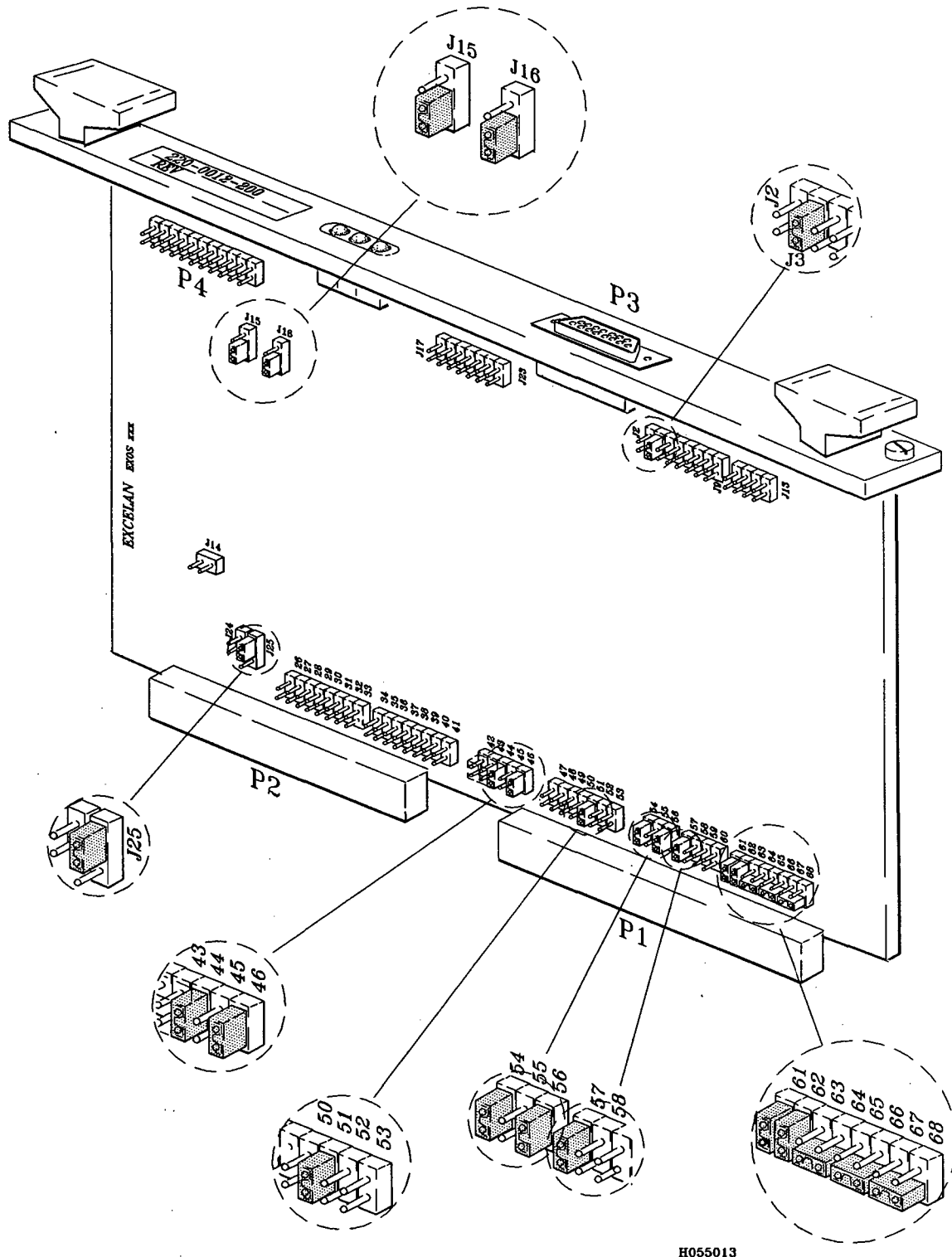

### 2.5.3 VMEbus Interrupt Request Jumper Setting

In the CONVEX system, the Ethernet controller *must* be configured for interrupt level 5. Jumper **J51** is used to select the proper interrupt level. See the previous figure for the location and jumper for interrupt level 5. Refer to the *EXOS 302 Reference Manual* for jumper configuration if other than level 5.

## 2.6 Removal and Installation

Because Ethernet controllers are located in the VMEbus chassis, the VMEbus chassis must be extended before replacing the controller. The following procedures detail the steps to extend the VMEbus chassis and install the Ethernet controller.

### 2.6.1 Extending the VMEbus Chassis

The following procedures describe the steps necessary to safely extend the VMEbus chassis from the expansion cabinet.

#### WARNING

System power must be **OFF** before performing any type of maintenance on the VMEbus chassis. Failure to do so may cause injury to personnel.

#### CAUTION

The system must be shut down to the SPU prompt before performing maintenance. Failure to shut down system before removing power will cause the loss of system data. Refer to the *CONVEX Processor Operation Guide* for the shutdown procedures for the CONVEX computer.

1. Remove all power to the VMEbus chassis by setting the power switch to the **OFF** position. The location of the power switch on the VMEbus chassis is shown in the following figure:

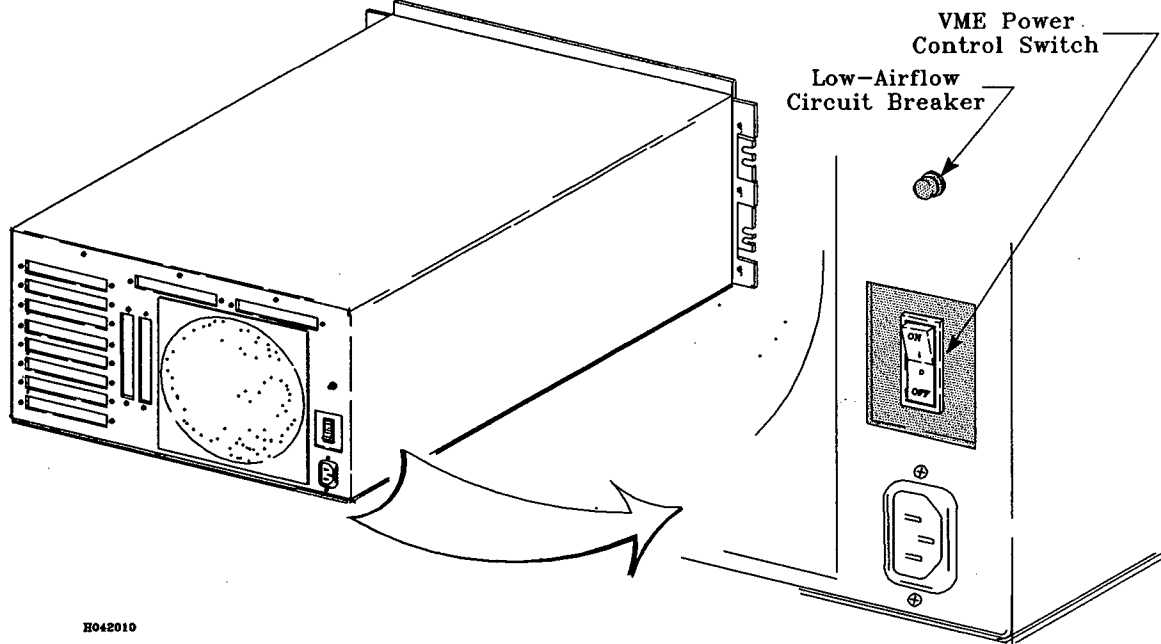
**Figure 2-6, VMEbus Chassis Power Switch**

R042010

**WARNING**

Expansion cabinet stabilizer bars must be extended before installing a VMEbus chassis or extending it forward on its slide guides for service. Failure to do so will make the expansion cabinet unstable, increasing the possibility of it falling forward. This may cause injury to personnel and/or damage to equipment.

2. Extend the expansion cabinet stabilizer bars to the full length of the bars.
3. Adjust the legs on the expansion cabinet stabilizer bars until they are in firm contact with the floor, as shown in the following figure:

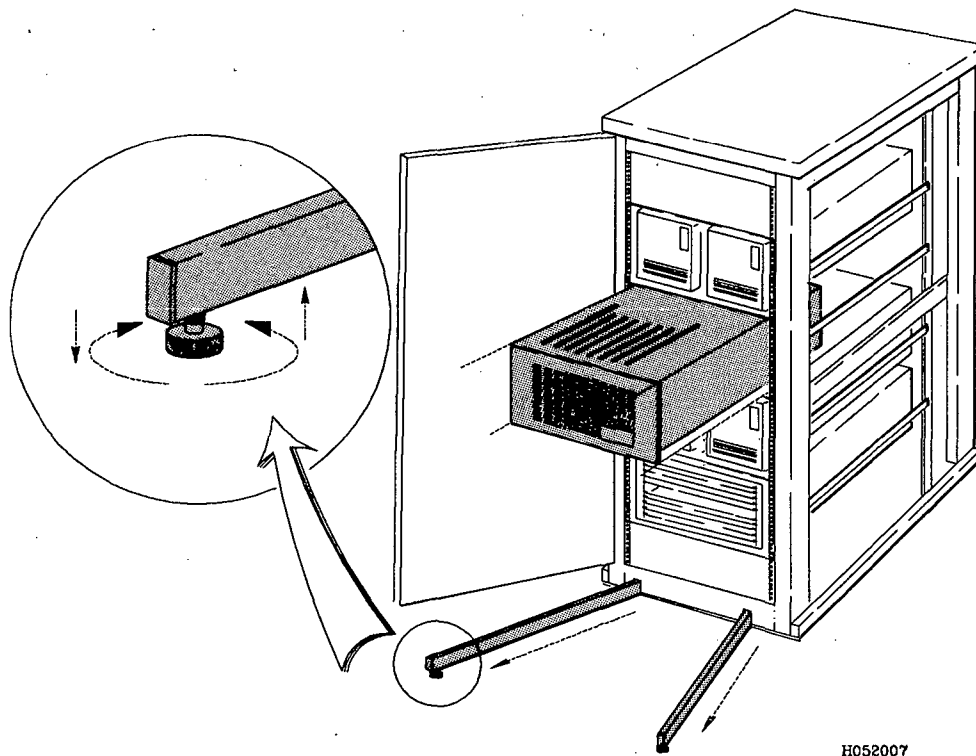
**Figure 2-7, Expansion Cabinet Stabilizer Bars**

4. Unlock the two chassis lock screws on the front of the VMEbus chassis.
5. Pull the VMEbus chassis out on the slide guides until the guide locks click in place.
6. Unscrew the top panel captive-mount screws until loose from the chassis frame. Lift the top panel from the VMEbus chassis to expose the VMEbus controller card cage.

### 2.6.2 Removing the Ethernet Controller

The procedures for removal are included in this manual to present the required steps for removing an already installed Ethernet controller.

#### CAUTION

Ensure the VMEbus chassis power switch is in the OFF position. Failure to observe this warning may result in severe damage to the board or system.

1. Ensure the VMEbus chassis power switch is **OFF**. See Figure 2-6, VMEbus Chassis Power Switch.
2. Two captive-mount screws are attached to the cable connector to prevent dropping of screws into the chassis. Unscrew these screws until loose from the controller frame.
3. Disconnect ribbon-cable 604-150004 end connector from top of Ethernet controller by lifting straight up on the connector, as shown in the following figure:

**Figure 2-8, Ethernet Board Removal**

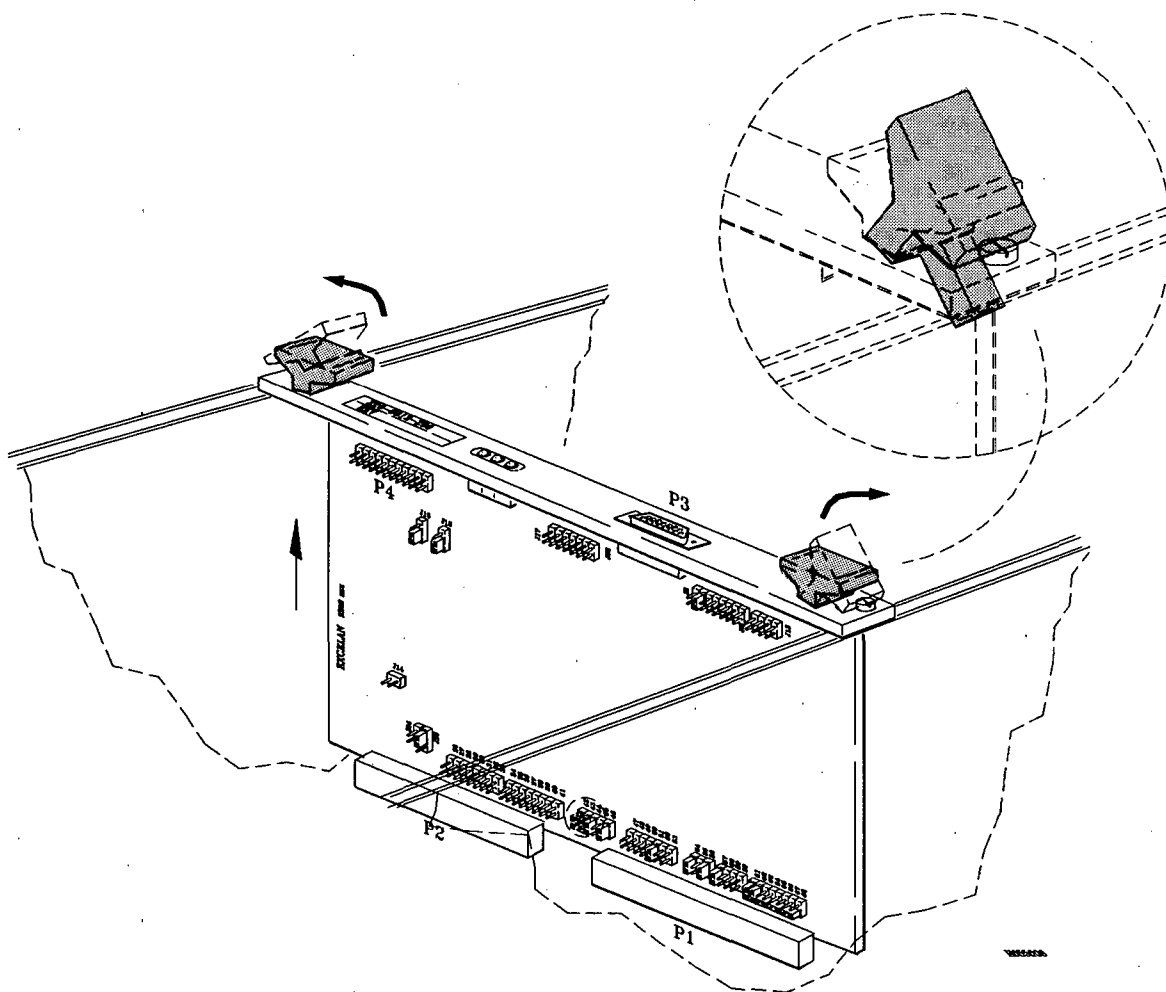

**CAUTION**

When the Ethernet controller is not installed in the VMEbus chassis, keep it in a conductive static shielding bag. Static bags provide protection from direct static discharge and from static fields surrounding charged objects. These bags are conductive and should not be placed where they may cause an electrical short circuit.

4. Lift the board from the chassis by pushing the handle on the top front of the board forward while at the same time pushing the top back handle toward the back of the chassis. This will gently lift the board from the connector on the VMEbus.
5. Pull the board the rest of the way out by lifting straight up from the chassis.

### 2.6.3 Installing the Ethernet Controller

Procedures for installing the Ethernet controller are described in detail to reflect the initial installation of the controller. Additional steps, such as the cable routing or connections, may not be necessary when replacing a controller. However, each step should be read when installing a controller to assure proper installation.

**CAUTION**

System power and VMEbus power must be **OFF** before the Ethernet controller can be installed. Failure to observe this warning may result in severe damage to the board or system.

1. Once the board is configured, ensure that both the system power and the VMEbus chassis power are **OFF**. See Figure 2-6, VMEbus Chassis Power Switch.

**NOTES**

A 10-inch or longer Phillips screw driver with a No. 1 point is required to install the 2 bottom screws in the single (6U) VMEbus circuit board adapter.

The single top screw is 2.5 mm.

2. Attach the single (6U) VMEbus circuit board adapter (with 2 screws) to the bottom of the chassis and (with 1 screw) to the top rear support rail, where the controller is to be installed, as shown in the following figure:

**Figure 2-9, Single (6U) VMEbus Circuit Board Adapter**

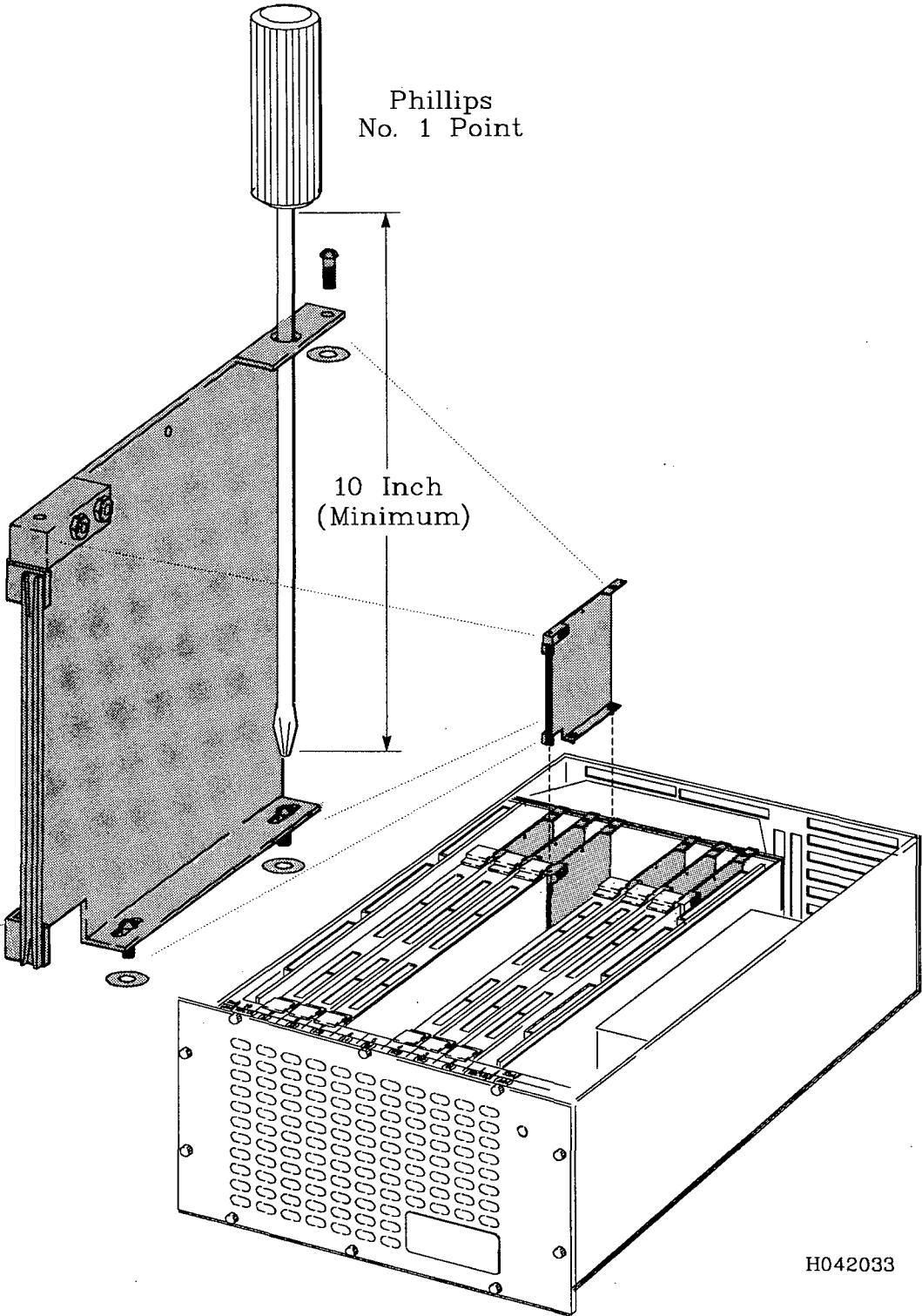

3. Install the Ethernet controller into the same slot as the VMEbus (6U) adapter in the VMEbus chassis, gently pushing down evenly on both ends of the board to prevent damage to the board pins.
4. Secure the board into position by tightening the two captive-mount screws on the top front and back of the board.

## 2.7 VMEbus Chassis Cable Scheme

VMEbus backplane slot positions are labeled on the front of each chassis. VMEbus controller cables exit the rear of the chassis through cable openings. Cable opening numbers are stamped on the rear panel of each VMEbus chassis. Cable routing, from the controller to the rear of the VMEbus chassis, should always follow a prescribed sequence. Cables from a given controller backplane slot position should always exit the VMEbus chassis at the same hole position. Cable openings and device types for each type of VMEbus chassis are defined in the following table:

**Table 2-3, Cable Opening Numbers for VMEbus Chassis**

Opening Number	Dual VMEbus	Single VMEbus	Combo VMEbus/Mbus
1	VBCU-0	VBCU	VBCU
2	VMEbus-0 Ctlr 1	Ctlr 1	VMEbus Ctlr 1
3	VMEbus-0 Ctlr 2	Ctlr 2	VMEbus Ctlr 2
4	VMEbus-0 Ctlr 3	Ctlr 3	VMEbus Ctlr 3
5	VMEbus-0 Ctlr 4	Ctlr 4	VMEbus Ctlr 4
6	VMEbus-1 Ctlr 4	Ctlr 5	VMEbus Ctlr 5
7	VMEbus-1 Ctlr 3	Ctlr 6	Mbus Ctlr 3
8	VMEbus-1 Ctlr 2	Ctlr 7	Mbus Ctlr 2
9	VMEbus-1 Ctlr 1	Ctlr 7 <sup>1</sup>	Mbus Ctlr 1
10	None	None	Mbus Ctlr 0
11	None	None	None
12	VBCU-1	None	MBCU

<sup>1</sup> This controller is the second board of a two-controller set. The first board is Ctlr number 7 in slot 8.

## 2.8 Ethernet Cable Connections

The following procedures discuss the cable installation on the Ethernet controller, attaching the transceiver to the system coaxial cable, and connecting the transceiver cable from the VMEbus chassis to the transceiver. The sequence of cabling presented is recommended for ease in handling the components in the installation process.

### CAUTION

When connecting a cable to a connector, always ensure the cable is installed firmly on the connector. Failure to connect the cable properly will render the controller inoperable.

### 2.8.1 Ethernet Ribbon-Cable Connection

1. Route the small end of ribbon-cable 604-150004 into the VMEbus chassis backplane slot corresponding to the Ethernet controller slot position. Refer to Table 2-3, Cable Opening Numbers for VMEbus Chassis.
2. Connect the small end of ribbon-cable 604-150004 to the single port on the Ethernet controller as shown in the following figure:

**Figure 2-10, Ethernet Controller Ribbon-Cable Connection**

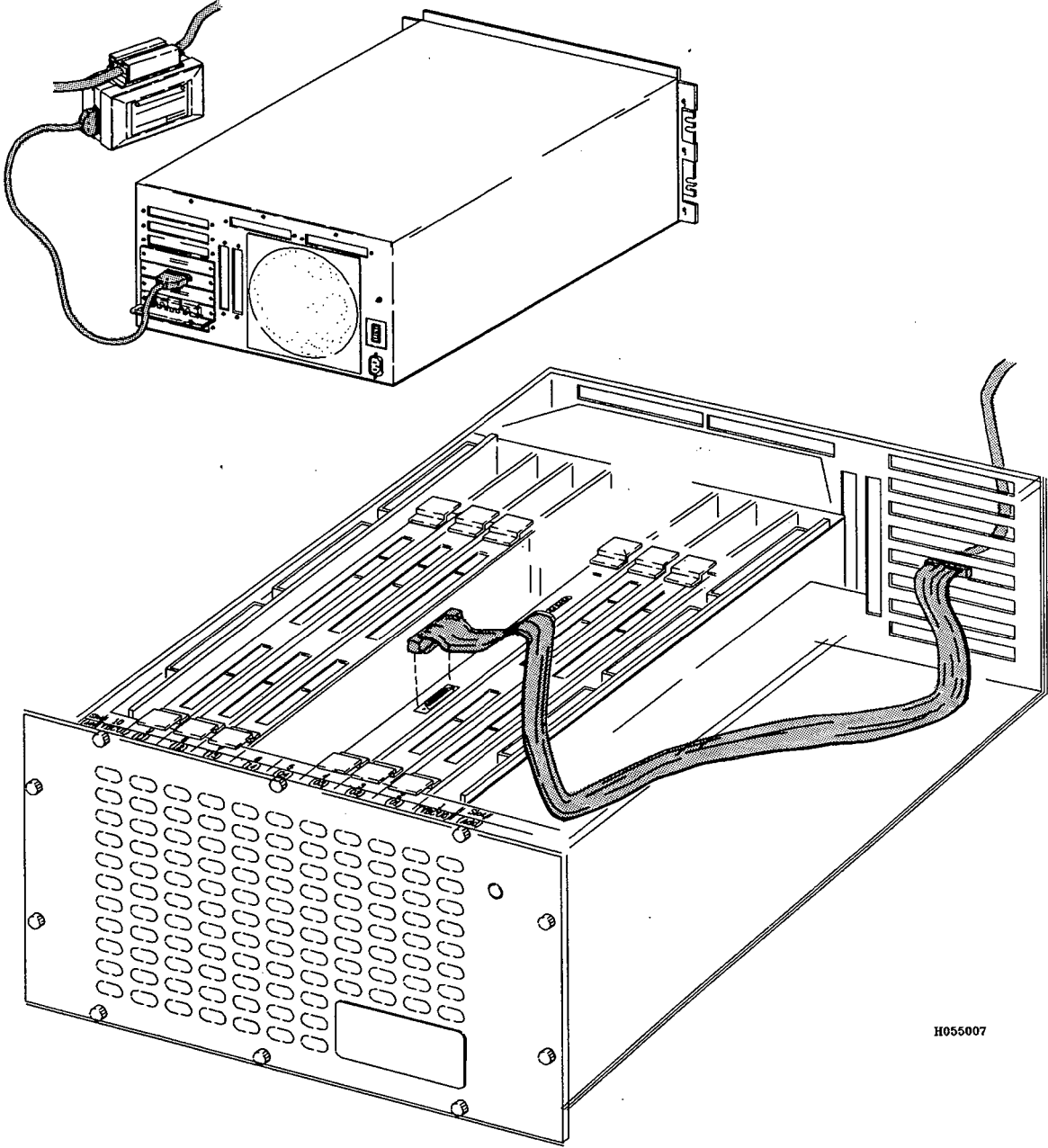

3. Secure the connector to the Ethernet controller port by sliding the two piece, slide-latch assembly over the locking posts.

4. Position the unconnected end of ribbon-cable 604-150004 (end with sheet-metal mount) to the matching controller slot position (refer Table 2-3, Cable Opening Numbers for VMEbus Chassis) on the outside, rear of the VMEbus chassis backplane as shown in the following figure:

**Figure 2-11, Ethernet Ribbon-Cable to VMEbus Chassis**

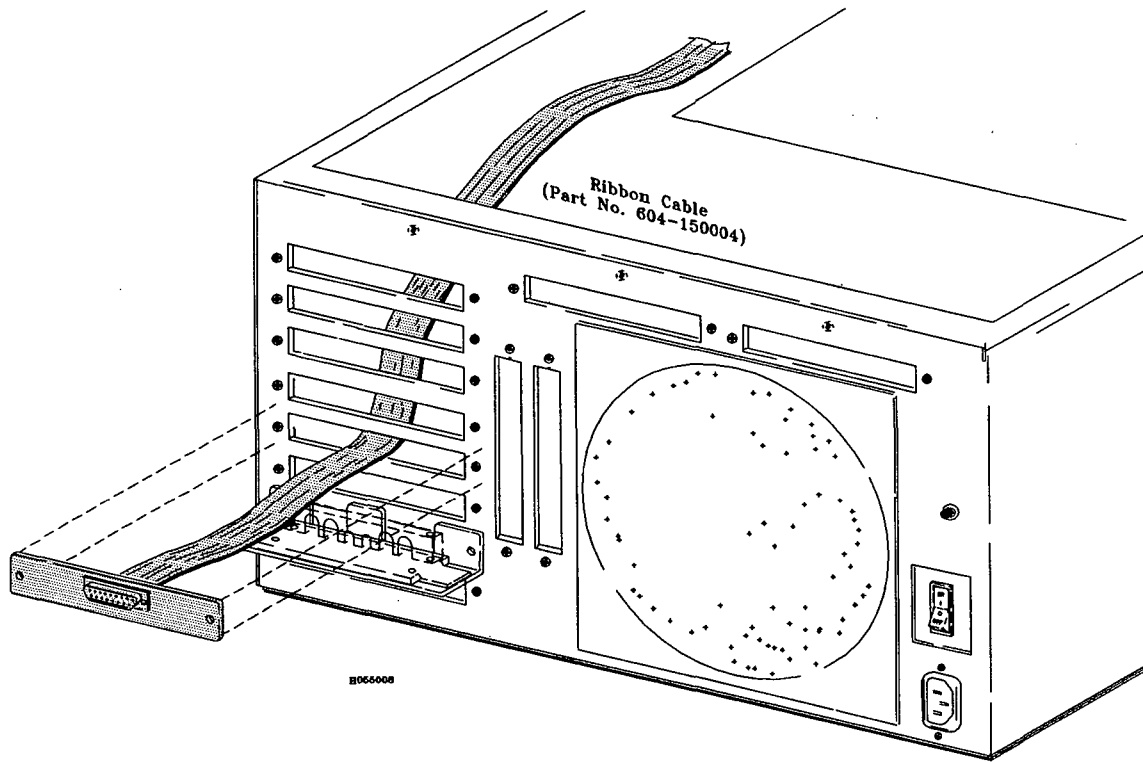

5. Attach the sheet-metal mount to the backplane using two mount screws shown in the previous figure.

### 2.8.2 Transceiver-to-Coaxial-Cable Connection

**NOTE**

Attach the transceiver unit to the coaxial cable before connecting the transceiver cable. This allows for easier handling of the transceiver unit and installation on the coaxial cable.

1. After removing the coaxial tap kit from the shipping container, review the accompanying instruction sheet.
2. Install the coaxial tap kit assembly onto the coaxial cable with assembly procedures from accompanying instruction sheet. See the following figure for proper configuration of components to the coaxial cable.

**Figure 2-12, Transceiver-to-Coaxial-Cable Connection**

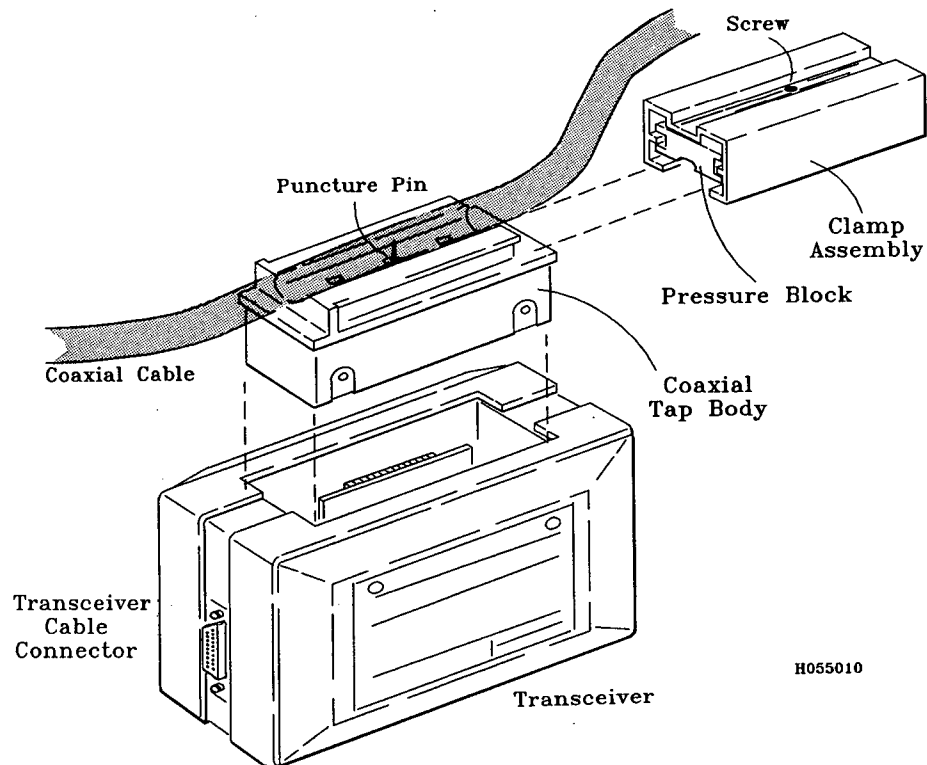

**CAUTION**

Care *must* be used when attaching the transceiver to the tap body. Terminators and probe assembly could be damaged if installed improperly.

3. Attach transceiver to connected coaxial tap kit. Refer to the accompanying instruction sheet.

### 2.8.3 Transceiver Cable Connection

1. Attach the female end of the transceiver cable to the transceiver unit connector.
2. Slide the D-connector slide latch assembly over the locking posts transceiver unit connector as shown in the following figure:

**Figure 2-13, Transceiver Cable Connection**

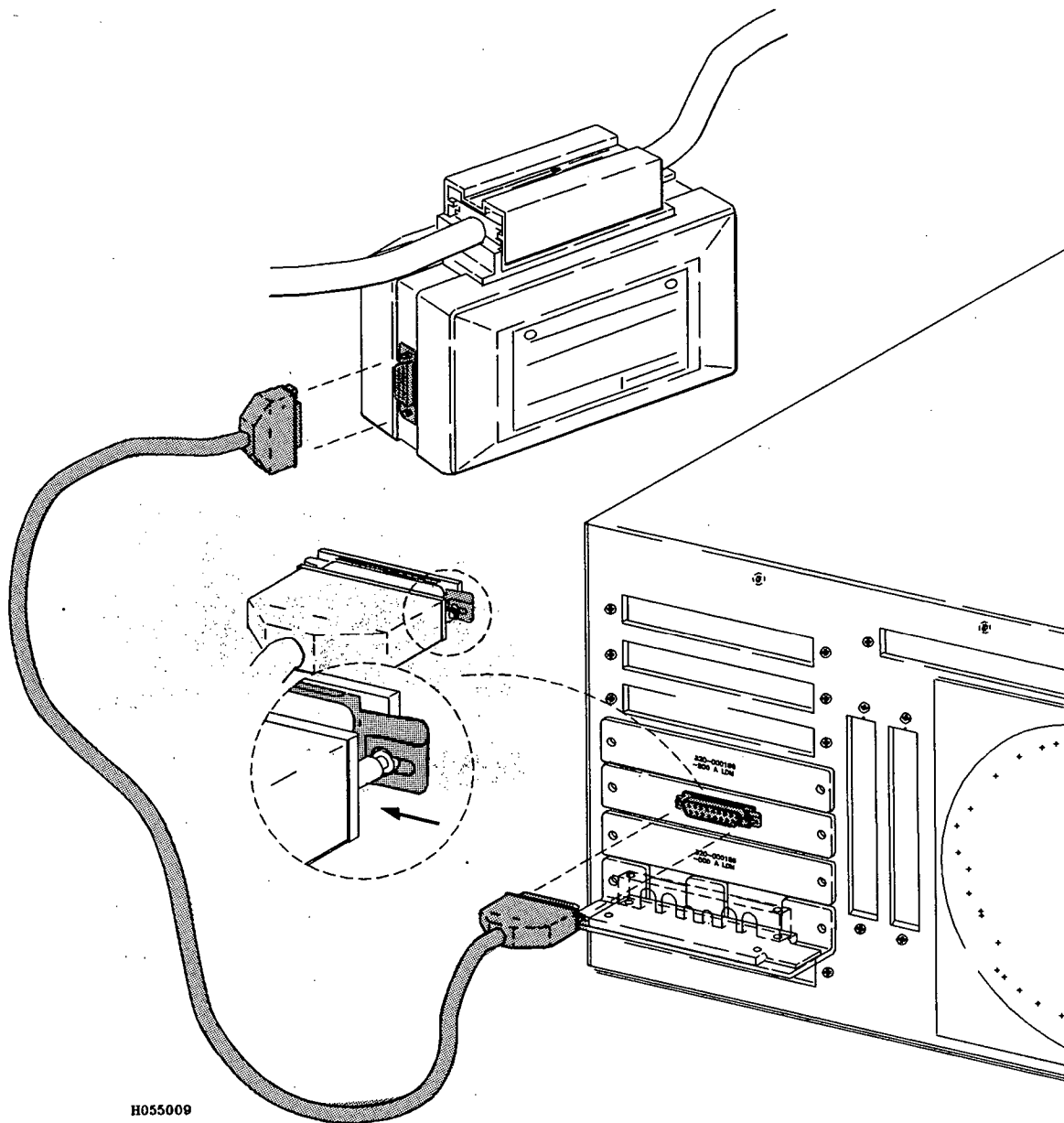

3. Route the unconnected end of transceiver cable 601001-50, using local cable routing, to the VMEbus chassis backplane.
4. Attach the unconnected end of transceiver cable 6010011-50 to the Ethernet female cable connector on the backplane of the VMEbus chassis.

5. Secure in place by sliding the slide latch assembly over the locking posts on the VMEbus chassis Ethernet connector as shown in the previous figure.

# Chapter 3

## Integration and Test

### 3.1 Overview

This chapter discusses the guidelines for integrating the Ethernet controller into the I/O subsystem and the diagnostic tests to operationally test the controller. The Ethernet controller must be integrated into the Operating System (OS) before being used.

### 3.2 Software Integration

CONVEX operating systems contain all software drivers for the hardware supported by CONVEX. This means that a system generation is not required when the VMEbus subsystem is installed on a CONVEX computer.

System-level hardware is identified to the CONVEX OS via a configuration file (*/ioconfig*) located on the Service Processor Unit (SPU) disk. The */ioconfig* file describes, in hierarchical fashion, the connections between VIOPs, VMEbus controllers, and peripheral devices. The OS uses this information to assign a physical device number to a controller.

Each type of controller is identified to the operating system by a mnemonic device code. The device code for the VMEbus Ethernet controller is LAN-007.

### 3.3 Example */ioconfig*

An Ethernet device code, and other information, are entered into the */ioconfig* file contained on the SPU disk. The I/O configuration file contains entries, such as VMEbus I/O Processor (VIOP) number, VMEbus chassis number, controller type, address and interrupt number, and peripheral device types. The OS uses this information during *sysgen* to assign a physical device number to a device of a given type. This enables the OS to associate a given physical device number (a storage module) with a specific base-unit sleeve.

The following is a typical */ioconfig* file that includes entries for VIOP 4 using three storage disks, two disk controllers, and one Ethernet controller in VMEbus 0:

---

**Figure 3-1, Example */ioconfig***

---

```

viop 4
  vme 0
    ctrl LAN-007 csr 0xFE00 int 5
      unit 0 type ex
    ctrl DKC-204 csr 0x400 int 2
      unit 0 type DKD-206
      unit 1 type DKD-208
    ctrl DKC-204 csr 0x600 int 3
      unit 0 type DKD-206
  vme 1
    ctrl DKC-203 csr 0x800 int 1
      unit 0 type DKD-214
      unit 1 type DKD-214
    ctrl DKC-203 csr 0xa00 int 2
      unit 0 type DKD-214
      unit 1 type DKD-214

```

---

Whenever an Ethernet controller is added or removed, the information in the hardware section of the configuration file (*/ioconfig*) must be changed, otherwise system operation problems will occur. Consult the *CONVEX System Manager's Guide* when making a change to this file.

### 3.4 Self-Test Operations

Reset of the Ethernet controller is by the host software or the VMEbus system reset. During any reset operation, the NX 300 firmware performs comprehensive tests to exercise the hardware and software components on the board. These tests determine if the board is functioning properly. Onboard diagnostics identify specific software or hardware problems associated with configuration and operation.

All Ethernet error conditions, including user software configuration and hardware errors, are handled by the NX 300 firmware. Additionally, NX 300 monitors for fatal hardware and software errors that may occur during the general network operation.

If any diagnostic test fails, errors are reported by an LED, making it possible to identify and correct the error. Specific errors are identified by a series of pulse signals via the LED. These signals equate to Morse code and are defined in the following table:

**Table 3-1, Self-Diagnostic/Configuration Error Codes**

<b>Self-Diagnostic/Configuration Error Codes</b>		
<b>Pulse Code</b>	<b>Hex Code</b>	<b>Error Code Explanation</b>
<b>Warnings</b>		
.--- ....	70H	Transceiver fuse failed or not present
.--- ...-	71H	Loopback test failed
.--- ..:	72H	-12 V supply failed
<b>Software-generated errors</b>		
-.: ....	A0H	Invalid address for configuration message
-.: .-.:	A4H	Invalid operation mode parameter
-.: .-:-	A5H	Invalid host data format test pattern
-.: .---	A7H	Invalid configuration message format
-.: -...:	A8H	Invalid movable data block parameter
-.: -.:-	A9H	Invalid number of processes parameter
-.: -.:	AAH	Invalid number of mailboxes parameter
-.: -.---	ABH	Invalid number of address slots parameter
-.: ---..	ACH	Invalid number host parameter
-.: ---:-	ADH	Invalid host queue parameter
-.: ----:	AEH	Improper objects allocation
-.: ----:	AFH	Net boot failed
<b>Hardware-generated errors</b>		
-.-- ...-	B1H	Memory test failed for 0-128 Kbytes
-.-- ..:	B2H	Memory test failed for 128 Kbytes to top of memory
-.-- .---	B3H	Counter test failed
-.-- .-..:	B4H	Interrupts test failed
-.-- .-:-	B5H	Transmission test failed
-.-- .---	B6H	Receive test failed
-.-- .---	B7H	Local loopback data path test failed
-.-- -...:	B8H	CRC test failed
-.-- -.:-	B9H	Checksum on physical address PROM failed
-.-- -.:	BAH	Bus error (parity or time-out)
-.-- -.---	BBH	Ethernet chip initialization failed
-.-- ---..	BCH	Ethernet chip self-test failed
-.-- ---:-	BDH	Ethernet chip resource counter failed
-.-- ----:	BEH	External loopback test alignment error

**Table 3-1, Self-Diagnostic/Configuration Error Codes  
(continued)**

<b>Self-Diagnostic/Configuration Error Codes</b>		
<b>Pulse Code</b>	<b>Hex Code</b>	<b>Error Code Explanation</b>
<b>Run-time errors</b>		
--.. ....	C0H	Specified time exhausted
--.. ...-	C1H	Host memory read/write test failed
--.. -...	C8H	Parity hardware logic failed
--.. -.-	C9H	NMI interrupt for bus time-out failed
--.. -.-.	CAH	Host interrupt test failed
--.. -.-	CBH	Command unit test failed
--.. ---.	CCH	Divide error exception
--.. ---	CDH	Undefined interrupt type
--.. ----	CEH	Command not executed by the CU of the 82586
--.. ----	CFH	Command block sync failed between hw and sw
---- ....	F0H	80286 segmentation fault

### 3.5 Diagnostics

Internal diagnostics of the Ethernet controller are executed automatically on power-up and software reset. Other diagnostics are available that should be used after performing maintenance on the controller. These diagnostics are discussed in depth in the *CONVEX PBUS I/O System Diagnostics Manual*. Refer to this manual when attempting to functionally test the operation of the Ethernet within the I/O subsystem.

# Appendix A

## Problem Reporting

### A.1 Overview

The *contact* utility is the recommended way to report minor hardware deficiencies and technical documentation problems to the Technical Assistance Center (TAC). This utility is an interactive tool that prompts the user for the information to properly file a problem report.

#### NOTE

The *contact* utility is not intended for requesting customer service for hardware failures. To restore your CONVEX equipment to operational status, faster service can be obtained by directly telephoning the TAC (refer to "Technical Assistance" in the Preface).

To use the *contact* utility, there must be a phone connection to the TAC. A UNIX-to-UNIX Communication Protocols (UUCP) allows communication between UNIX systems by either dial-in or hard-wired communication lines. For more information, refer to *uucp(1)* or to the *info(1)* entry in the UNIX man pages.

The name and version number of the product involved is required. Use the *vers* command to ascertain the program or utility name and version. The syntax for the command is *vers filename*, where *filename* is the full pathname of the program. If the full pathname of the program is not known, enter **which program**. For more information, refer to the *vers(1)* and *which(1)* entries in the UNIX man pages.

### A.2 Information Required to Report a Problem

The *contact* utility requires the following information:

1. The customer name, title, phone number, and corporate name
2. The hardware nomenclature, part number, and revision level, or the technical manual name, document number, and version

#### NOTE

Use *vers* and *which* to identify product name and version.

3. A short (one line) summary of the problem

4. The more information provided, the more quickly the problem can be isolated and solved. At a minimum, include a detailed description of the problem (including page references, if applicable), the source code, and a stack backtrace whenever possible.

**NOTE**

See the *adb(1)* or *csd(1)* man pages for information on obtaining stack backtraces.

5. The priority of the problem, selected from a list of six levels
6. Instructions on how to reproduce the problem, including the command syntax used, any flags invoked, or anything else attempted to make the program run
7. Any other comments about the problem or files to be submitted

The *contact* user has a chance to review and edit the report prior to submitting it. If the user decides to delay submitting the report, the session can be aborted. The report is automatically saved in the user's top-level directory in a file named *dead.report*.

See the following figure for a sample *contact* session. User input is in bold lettering, and the system response is in monospace type.

**Figure A-1, Sample *contact* Session**

---

```
%contact (RETURN)
Welcome to contact version 0.11 ()

Enter your name, title, phone number, and corporate name (^D to terminate)
> Margaret Atwood, systems programmer, 814-4444, University r
> of Chicago (RETURN)
> (CTRL-D)

Enter the name of the product involved
> CONVEX UNIX Programmer's Manual, Part I (RETURN)

Enter the version number (in the form X.X or X.X.X.X) of the product
> Revision 4.0 (RETURN)

Enter a short (1 line) summary of the problem
> The finger command manual page lists nonexistent bug (RETURN)

Enter a detailed description of the problem (^D to terminate)
> The finger(1) man page says, under the BUGS section, that "Only the first
line of the .project file is printed." Happily, this is not true! (RETURN)
> (CTRL-D)

Enter a problem priority, based on the following:
1) Critical - work cannot proceed until the problem is resolved.
2) Serious - work can proceed around the problem, with difficulty.
3) Necessary - problem has to be fixed.
4) Annoying - problem is bothersome.
5) Enhancement - requested enhancement.
6) Informative - for informational purposes only.
> 4 (RETURN)

Enter the instructions by which the problem may be reproduced (^D to terminate)
> a) put more than one line in .project (RETURN)
> b) read the man page for finger(1) (RETURN)
> (CTRL-D)

Enter any comments that are applicable (^D to terminate) (RETURN)
> (CTRL-D)

Do you have any suggestions or comments on the documentation that you
referenced when you were trying to resolve your problem (for example,
additions, corrections organization, accessibility)? (^D to terminate)
> The man page should be updated. (RETURN)
> (CTRL-D)

Are there any files that should be included in this report (yes | no)?
> no (RETURN)

Please select one of the following options:
1) Review the problem report.
2) Edit the problem report.
3) Submit the problem report.
4) Abort the problem report.
> 3 (RETURN)

Problem report submitted.
%
```

---

**THIS PAGE INTENTIONALLY LEFT BLANK**

# Index

- A**  
Adapter assembly, VMEbus (6U) PCB, illustrated 2-13  
Address FD80 2-3  
Address FE00 2-4  
Address FE80 2-5  
Address FF00 2-6  
Address jumper positions, table 2-3  
Associated documentation, ordering viii  
Associated documents, listed viii
- B**  
Base address jumper selection 2-3
- C**  
Cable opening numbers, defined 2-15  
Configuration, discussed 2-2  
*contact*, for reporting problems A-1  
CONVEX standard ethernet jumper settings 2-7  
Customer support, telephone numbers for ix
- D**  
Damage claims, discussed 2-1  
Data-link layer functions, discussed 1-2  
*dead.report*, *contact* file A-2  
Diagnostics, discussed 1-7  
Diagnostics, reference to 3-4  
Document numbers, format, in preface viii  
Documents, ordering, how to viii
- E**  
Electrostatic discharge, discussed 2-2  
Ethernet architecture 1-3  
Ethernet cable connections, discussed 2-16  
Ethernet controller address jumper positions 2-3  
Ethernet controller ribbon-cable connection, illustrated 2-16  
Ethernet ribbon-cable to VMEbus chassis, illustrated 2-18  
Europe, technical assistance, how to obtain ix  
Expansion cabinet stabilizer bars 2-10
- F**  
Front-end mode, discussed 1-4  
Functional description 1-3
- H**  
Hardware features 1-1
- I**  
*info(1)*, man page A-1  
Installation, discussed 2-13  
Integration and test, overview 3-1  
*/ioconfig* file, example 3-1
- J**  
Jumper configuration, common settings 2-3
- L**  
Link-level mode, discussed 1-4
- M**  
Modems, with *contact* A-1
- N**  
Notational conventions, discussed vii
- O**  
Ordering documents, how to viii  
Overview, configuration and installation 2-1  
Overview, description 1-1  
Overview, integration and test 3-1  
Overview, problems, reporting A-1
- P**  
Packaging, inspection of 2-1  
Part numbers. *See* Document numbers  
Problems, reporting A-1
- R**  
Removal and installation 2-9  
Removal of Ethernet controller 2-11  
Request/grant jumper selection 2-7  
Revision sheet iii
- S**  
Specifications for EXOS 302 1-7  
Static charge levels, defined 2-2
- T**  
TAC, reporting problems to A-1  
Technical assistance ix  
Technical Assistance Center. *See* TAC  
Technical Assistance Center, telephone numbers for ix  
Trouble reports ix
- U**  
UNIX-to-UNIX Communication Protocols, with *contact* A-1  
UUCP. *See* UNIX-to-UNIX Communication Protocols  
*uucp(1)*, man page A-1
- V**  
*vers* A-1  
VMEbus (6U) adapter, assembly, illustrated 2-13  
VMEbus chassis cable opening numbers, defined 2-15  
VMEbus chassis cabling scheme, discussed 2-15  
VMEbus chassis, extending of 2-9  
VMEbus EXOS 302 specifications 1-7

VMEbus interrupt request jumper setting 2-9  
Voltage charge determination 2-2

**W**  
*which* A-1

**CONVEX VMEbus Ethernet Controller  
Service Guide  
Document No. 081-000630-200, First Edition**

**Reader's Forum**

You are invited to submit comments concerning the clarity and service of this manual. Constructive critical comments are most welcome, and will help us continue in our efforts to generate quality customer documentation. Please list the document page number with your questions and comments.

---

---

---

---

---

---

---

---

---

---

**From:**

Name \_\_\_\_\_ Title \_\_\_\_\_

Company \_\_\_\_\_ Date \_\_\_\_\_

Address and Phone No. \_\_\_\_\_

**FOR ADDITIONAL INFORMATION OR DOCUMENTATION:**

Location	Phone Number
In Texas	(214)952-0200
Other continental locations	1(800)952-0379
Outside continental US	Contact local CONVEX office

Direct mail orders to:

CONVEX Computer Corporation  
Customer Service  
PO Box 833851  
Richardson TX 75083-3851 USA

(Fold Here First)



NO POSTAGE  
NECESSARY  
IF MAILED  
IN THE  
UNITED STATES

**BUSINESS REPLY MAIL**

FIRST CLASS PERMIT NO. 1046 RICHARDSON, TEXAS

POSTAGE WILL BE PAID BY ADDRESSEE

CUSTOMER SERVICE  
CONVEX Computer Corp.  
P.O. Box 833851  
Richardson, TX 75083-3851

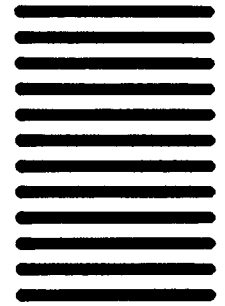

(Fold Here Second)

(Tape or Staple)